

RedBin-D Transmitter for ExPro-B... Temperature / humidity sensors

| |
|-------------------|
| RedBin - D |
| RedBin - D - 2 |
| RedBin - ... - CT |
| RedBin - ... - VA |

Subject to change!

Electrical, explosion-proof transmitters with ExPro-B... sensors
 24 VAC/DC supply voltage, potential free relay output
 EC type-approved in acc. with ATEX directive 2014/34/EU for zone 2, 22

Compact. Easy installation. Universal. Cost effective. Safe.

| Type | Sensors (compulsory) | Function of sensors | Supply | Output | Wiring diagram | Installation area |
|-------------------|--|---------------------|-----------|-------------------|----------------|-------------------|
| RedBin- D | ExPro-B... (see below) | °C, % rH, °C+% rH | 24 VAC/DC | Relay contact | SB 1.0 | Zone 2, 22 |
| RedBin- D - 2 | as above with additional relay switching output | | | 2 × Relay contact | SB 2.0 | Zone 2, 22 |
| RedBin- D... - CT | Types as above with aluminium housing and seawater resistant coating (cable glands M16 brass nickel-plated, screws in stainless steel) | | | | | |
| RedBin- D... - VA | Types as above with stainless steel housing for aggressive ambient (cable glands M20 brass nickel-plated, screws in stainless steel) | | | | | |

| Type | Function | Range | Probe/sensor length | Connection | Installation area sensor |
|--------------|--------------------|-------------------------------|-------------------------|--|--------------------------|
| ExPro-BT... | Temperature sensor | -40...+125 °C* | 50 / 100 / 150 / 200 mm | Plug and socket to ExBin-D..., RedBin-D... | Zone 1, 2, 21, 22 |
| ExPro-BF... | Humidity sensor | 0...100 % rH | 50 / 100 / 150 / 200 mm | Plug and socket to ExBin-D..., RedBin-D... | Zone 1, 2, 21, 22 |
| ExPro-BTF... | Combination sensor | -40...+125 °C* / 0...100 % rH | 50 / 100 / 150 / 200 mm | Plug and socket to ExBin-D..., RedBin-D... | Zone 1, 2, 21, 22 |

↑ Sensor length * at 50 mm length -40...+80 °C

Product views and applications Figures ...Bin-D-2



Description

The RedBin-D... transmitter generation with directly coupled ExPro-B... sensors is a revolution for measuring temperature and/or humidity in HVAC systems, in chemical, pharmaceutical, industrial and offshore/onshore plants, for use in hazardous areas zone 2 (gas) and zone 22 (dust). Highest protection class (ATEX) and IP66 protection, small dimensions, universal functions and technical data guarantee safe operation even under difficult environmental conditions.

All sensors are programmable on site without any additional tools. The switching points are scalable within the maximum ranges. The integrated display (can be switched off as needed) is for parametrisation and an actual value indication at working mode.

...Bin-D-2 transmitter are additionally equipped with a second switching output, which can be parameterized independently.

Highlights

- ▶ For all types of gases, mists, vapours and dust for use in zone 2 and 22
- ▶ Power supply 24 VAC/DC
- ▶ Scalable, potential free switching contact
- ▶ Integrated Ex terminal box
- ▶ No additional Ex-i module required
- ▶ No intrinsically safe wiring/installation between panel and sensor required
- ▶ No intrinsically safe wiring/installation and no space in the panel required
- ▶ Optional second switching output
- ▶ Display with backlight, can be switched off
- ▶ Password locking
- ▶ Down to -20 °C ambient temperature applicable
- ▶ Compact design and small dimension
- ▶ Robust aluminium housing (optional with seawater resistant coating) or in stainless steel
- ▶ IP66 protection

ExPro-B – see additional data sheet



| Technical data | ...Bin- D | ...Bin- D- 2 |
|--------------------------------------|--|--------------|
| Supply voltage, frequency | 24 VAC/DC $\pm 20\%$ (19,2...28,8 VAC/DC), 50/60 Hz | |
| Current, power consumption | 150 mA, ~ 4 W, internal fuse 500 mA, without bracket, not removable | |
| Galvanic isolation | Supply for relay output min. 1,5 kV | |
| Electrical connection | Terminals 0,14...2,5 mm ² at integrated Ex terminal box, stripping length 9 mm, torque 0,4...0,5 Nm, equipotential bonding 4 mm ² | |
| Cable glands | 2 x M16 x 1,5 mm, Ex approved, for cable diameter ~ \varnothing 5...9 mm | |
| Cable glands ...-CT | 2 x M16 x 1,5 mm, Ex approved, brass nickel-plated, for cable diameter ~ \varnothing 6...10 mm | |
| ...-VA | 2 x M20 x 1,5 mm, Ex approved, brass nickel-plated, for cable diameter ~ \varnothing 6...13 mm | |
| Protection class | Class I (grounded) | |
| Display | Matrix LCD, backlit, for configuration, user guidance, parameter and actual value indication. Status indicator via LEDs | |
| Control elements | 3 buttons for configuration | |
| Housing material | Aluminium die-cast housing, coated. Optional with seawater resistant coating (...-CT) or stainless steel housing, № 1.4581 / UNS-J92900 / similar AISI 316Nb (...-VA) | |
| Dimensions (L x W x H) | Aluminium housing ~ 180 x 107 x 66 mm, stainless steel housing ~ 195 x 127 x 70 mm (each without connectors) | |
| Weight | ~ 950 g aluminium housing, stainless steel version ~ 2,5 kg | |
| Ambient temperature | -20...+50 °C, storage temperature -35...+70 °C | |
| Temperature class | Aluminium housing T6 (T80 °C) at -20...+50 °C Stainless steel housing T5 (T95 °C) at -20...+40 °C, T4 (T130 °C) at -20...+50 °C | |
| Ambient humidity | 0...95 % rH, non condensing | |
| Sensor connection | For ExPro-B... sensor only! Via plug-and-socket connection at front side (for room mounting) or at back side (for duct mounting). Attention: Only 1 ExPro-B... sensor per transmitter can be connected! | |
| ExPro-B... sensors | More information of connectable ExPro-B... sensors see separate data sheet | |
| Measuring range | -40...+125 °C / 0...100 % rH, non condensed | |
| Response time of sensor | T90 / ~ 3 s | |
| Relay output accuracy | $\pm 0,1$ °C resolution + accuracy of ...Pro-B... sensor | |
| Humidity | $\pm 0,05\%$ resolution + accuracy of ...Pro-B... sensor | |
| Setting range hysteresis | +0,5...+20,0 °C (factory setting +1,0 °C) / 0,5...20,0 % rH (factory setting 5,0 % rH) | |
| Start delay | 5 s | |
| Stability | Long term stability < 0,2 %/year, temperature influence < 0,02 %/K, supply voltage influence < 0,01 % | |
| Output | Potential free switching contact – breaking/making contact, adjustable per menu | |
| max. rating load | 0,5 A (30 VAC/DC) – 0,1 A (250 VAC) – 0,1 A (220 VDC). Power 40 W, 10 W per channel | |
| min. rating load | 10 mW / 0,1 V / 1 mA | |
| Additional relay output (Type ...-2) | – | as above |
| Duration of life | 10 x 10 ⁶ | |
| Mechanical | 100 x 10 ³ | |
| Electrical (rated load) | | |
| Wiring diagram | SB 1.0 | SB 2.0 |
| Scope of delivery | Transmitter, 3 self-tapping screws 4,2 x 13 mm resp. in stainless steel (with ...CT and ...VA versions) | |

Special solutions and accessories

| | |
|------------|---|
| ...-CT | Types in aluminium housing with seawater resistant coating, parts nickel-plated |
| ...-VA | Types in stainless steel housing, parts nickel-plated |
| MKR | Mounting bracket for round ducts up to \varnothing 600 mm |
| Kit-S8-CBR | 2 cable glands M16 x 1,5 mm, Ex-e, brass nickel-plated, for cable \varnothing 5...10 mm |

CSA – Hazardous Location – EMPLACEMENTS DANGEREUX



This equipment is suitable for installation in Class I, Division 2, Group A, B, C, D hazardous locations or nonhazardous locations only.
CET ÉQUIPEMENT EST SEULEMENT APPROPRIÉ À L'INSTALLATION DANS LA CLASSE I, DIVISION 2, GROUPES A, B, C, D DES EMPLACEMENTS DANGEREUX OU DES EMPLACEMENTS NON DANGEREUX.



WARNING – EXPLOSION HAZARD:
Substitution of components may impair suitability for Class I, Division 2.
AVERTISSEMENT – RISQUE D'EXPLOSION :
LA SUBSTITUTION DE COMPOSANTS PEUT RENDRE CE MATÉRIEL INACCEPTABLE POUR LES EMPLACEMENTS DE CLASSE I, DIVISION 2.



WARNING – EXPLOSION HAZARD:
Do not connect or disconnect this equipment unless power has been removed or the area is known to be nonhazardous.
AVERTISSEMENT – RISQUE D'EXPLOSION :
NE PAS BRANCHER OU DÉBRANCHER TANT QUE LE CIRCUIT EST SOUS TENSION, À MOINS QU'IL NE S'AGISSE D'UN EMPLACEMENT NON DANGEREUX.



Electrical connection

All transmitters require a 24 VAC/DC power supply. The electrical wiring must be realized via the integrated terminal box acc. to ATEX.

Attention: Before opening the terminal box cover, the supply voltage must be shut off! The supply has to be connected at terminals 1 (-/~) and 2 (+/~).

Warning icon: At different relay and supply voltages (24 VAC/DC) the cable installation must be considered (see "Information for Installation")!

Depending on the ...Pro-B... sensor's type you can measure either temperature (...Pro-BT...) or humidity (...Pro-BF...) at the time or combined with a ...Pro-BTF... Simultaneous measurings are not possible, use only one transmitter at the time.

Before starting parametrisation of ...Bin-D... transmitter a ...Pro-B... sensor must be connected, which can be mounted either to the front or the back side of the transmitter. The protective cap must be removed.

Unused connectors must be covered with the original protective cap to avoid mechanical damage and dirt!

Depending on the sensor's type you need to set parameters for one or two measuring ranges and their related data.

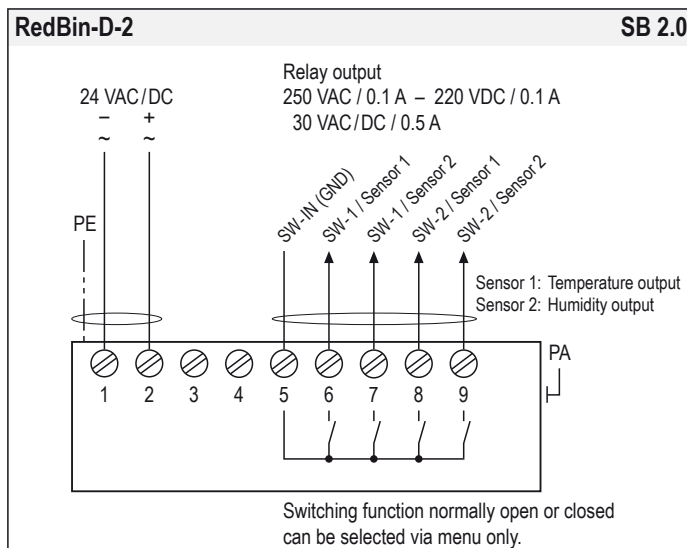
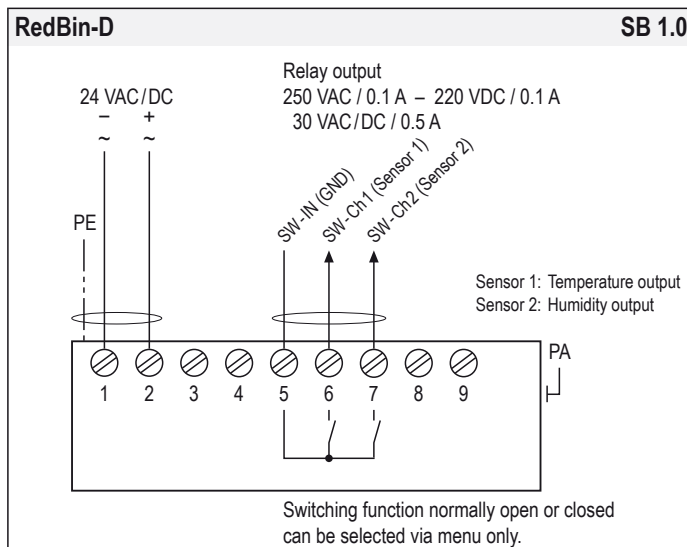

Intrinsically safe parameters (IS) – Internal values

Table with 4 columns: Uo, Io, Po, and IIC/IIB/IIA. Values: Uo = 7.9 V, Io = 6.4 mA, Po = 12.7 mW, IIC = 5 mH, IIB = 10 mH, IIA = 20 mH, Ci -> 0, Li -> 0, Co = 1.5 uF, 6.7 uF, 8.6 uF.

Important information for installation and operation

A. Installation, commissioning, maintenance

All national and international standards, rules and regulations must be complied with. Certified apparatus must be installed in accordance with manufacturer instructions. If the equipment is used in a manner not specified by the manufacturer, the safety protection provided by the equipment may be impaired. For electrical installations design, selection and erection, EN/IEC 60079-14 can be used.

Canada: Install per Canadian Electrical Code (CEC). USA: Install per National Electrical Code (NEC).

Attention: Apply all Ex rules and regulation before opening the internal terminal box. Do not open cover when circuits are live!

Draw the wiring cables through the cable glands. For connection use the internal Ex terminal box and connect equipotential bonding.

After connection install the cables in a fixed position and protect them against mechanical and thermal damage. Close all openings and ensure IP protection (min. IP66).

Avoid temperature transfer and ensure not to exceed max. ambient temperature! For outdoor installation a protective shield against sun, rain and snow should be applied. Sensors are maintenance free. An annual inspection is recommended. For electrical installations inspection and maintenance, EN/IEC 60079-17 can be used.

Clean with damp cloth only.

Ex sensors must not be opened and repaired by the end user.

B. Long cabling

We recommend using shielded signal wires and to connect one end of the shield to the ...Bin... terminal box.

C. Separate ground wires

For supply and signal wires use separate grounds.

D. Relay output

Wires for safety extra-low voltage must be installed separately from other circuits. At 24 VAC/DC only supply and signal wires are permitted in one cable, in all other cases use separate or double isolated cables. An over-current protection fuse < 10 A has to be provided by the installer.

E. ExPro-B... sensors

The ExPro-B... sensor is supplied by the transmitter's intrinsically safe circuit. Unused connectors must be covered with a protective cap.



Display, buttons and parameters

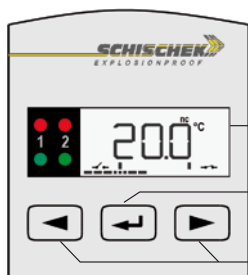

Display for programming and indication

Push button ENTER

Push button for level selection

Fig. ...Bin-D-2

Indication of data logging

The flashing unit symbol (°C) shows that data is received and the device is working.

Sensor malfunction

A sensor malfunction is indicated by a red flashing LED and the text "SENS" in the display. The switching outputs will indicate that, too. In this case the connection between the transducer and the sensor should be checked first.

Password input

The default/delivery setup is 0000. In this configuration the password input is not activated. To activate the password protection (menu 15) change the 4 digits into your choosen numbers (e.g. 1234) and press ENTER.

Please keep your password in mind for next parameter change! Due to a new parameter setup the password is requested.

Change operation – parametrisation mode

To change from operation to parametrisation mode and vice versa, push [ENTER] button for minimum of 3 seconds. Back to operation mode with menu "save".

Parametrisation and commissioning

To change from operation to parametrisation mode push the "ENTER" button [ENTER] for minimum 3 seconds.

If password protected: type password and push [ENTER].

Skip menu with [right arrow], back to operation mode with menu "save".

Operation → Parametrisation push [ENTER] for min. 3 s

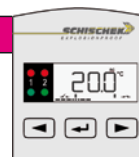

| Menu | Function | ENTER | Indication | Select | ENTER | Next indication | Select | ENTER | Next menu |
|---------|---|--------------------|----------------|-----------------------|-------|---------------------------------------|-----------------------|-------|-------------------------------|
| Menu 1 | no function – menu skip | | | | | | | | |
| Menu 2 | Unit sensor Select physical unit | [Menu 2+] [ENTER] | Menu 2 °C | [left] [right] [left] | | °C, °F | [right] | | [right] |
| Menu 3 | set 1, sensor 1 Select switching point 1 (temperature) | [Menu 3+] [ENTER] | Menu 3 200 °C | [left] [right] [left] | | enter temperature | [right] | | [right] |
| Menu 4 | set 2, sensor 1 (optional) * Select switching point 2 (temperature) | [Menu 4+] [ENTER] | Menu 4 300 °C | [left] [right] [left] | | enter temperature | [right] | | [right] |
| Menu 5 | hysteresis, sensor 1 Select hysteresis | [Menu 5+] [ENTER] | Menu 5 10 °C | [left] [right] [left] | | enter degrees | [right] | | [right] |
| Menu 6 | mode, sensor 1 Select switching properties (break contact, make contact) | [Menu 6+] [ENTER] | Menu 6 UP | [left] [right] [left] | | Up, Down, Mid * | [left] [right] [left] | | [right] |
| Menu 7 | Unit sensor Select physical unit | [Menu 7+] [ENTER] | Menu 7 %rF | [left] [right] [left] | | % rF, % rH | [right] | | [right] |
| Menu 8 | set 1, sensor 2 Select switching point 1 (humidity) | [Menu 8+] [ENTER] | Menu 8 500 %rF | [left] [right] [left] | | enter humidity % | [right] | | [right] |
| Menu 9 | set 2, sensor 2 (optional) * Select switching point 2 (humidity) | [Menu 9+] [ENTER] | Menu 9 800 %rF | [left] [right] [left] | | enter humidity % | [right] | | [right] |
| Menu 10 | hysteresis, sensor 2 Select hysteresis | [Menu 10+] [ENTER] | Menu 10 50 %rF | [left] [right] [left] | | enter humidity % | [right] | | [right] |
| Menu 11 | mode, sensor 2 Select switching properties (break contact, make contact) | [Menu 11+] [ENTER] | Menu 11 Mid | [left] [right] [left] | | Up, Down, Mid * | [left] [right] [left] | | [right] |
| Menu 12 | no function – menu skip | | | | | | | | |
| Menu 13 | display setting Select display | [Menu 13+] [ENTER] | Menu 13 ON | [left] [right] [left] | | on, off | [right] | | [right] |
| Menu 14 | no function – menu skip | | | | | | | | |
| Menu 15 | security Select password protection | [Menu 15+] [ENTER] | Menu 15 0000 | [left] [right] [left] | | enter password | [right] | | [right] |
| Menu 16 | save Select: save data, discard, back to menu, factory setting | [Menu 16+] [ENTER] | Menu 16 YES | [left] [right] [left] | | Yes, no, menu, dset (default setting) | [right] | | (operation mode after "save") |

* for ...Bin-D-2 only (2-stage)



Menu 6 "mode" – Switching properties

1. Define the device's normal range first:

- The device should indicate (green LED) when the temperature/humidity is
 - above the setpoints – mode „up-range“ has to be selected.
 - below the setpoints – mode „down-range“ has to be selected.
 - between the setpoints – mode „mid-range“ has to be selected.
- This mode is available for 2-stage devices only (...Bin-D-2).

2. Select the switching characteristic of the output relay:

- When the measured value is in normal range, the corresponding relays shall
 - close – select "normally closed" (nc)
 - open – select "normally open" (no)

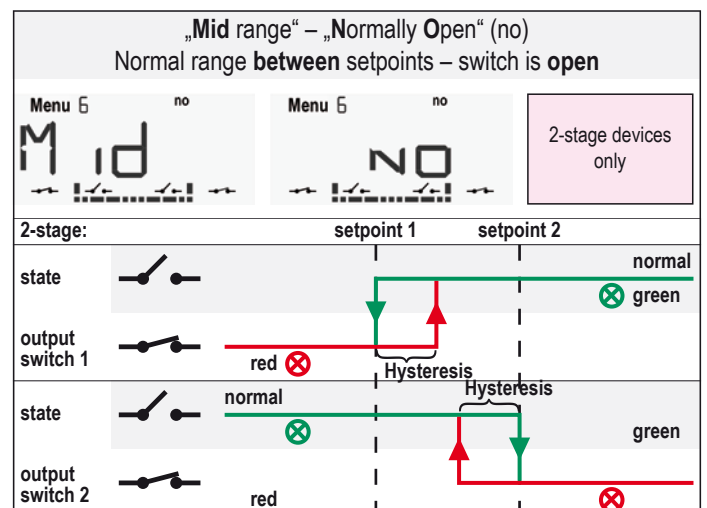
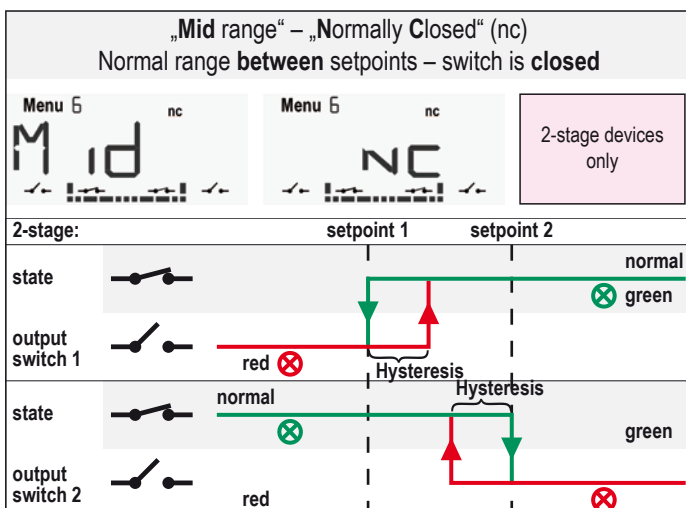
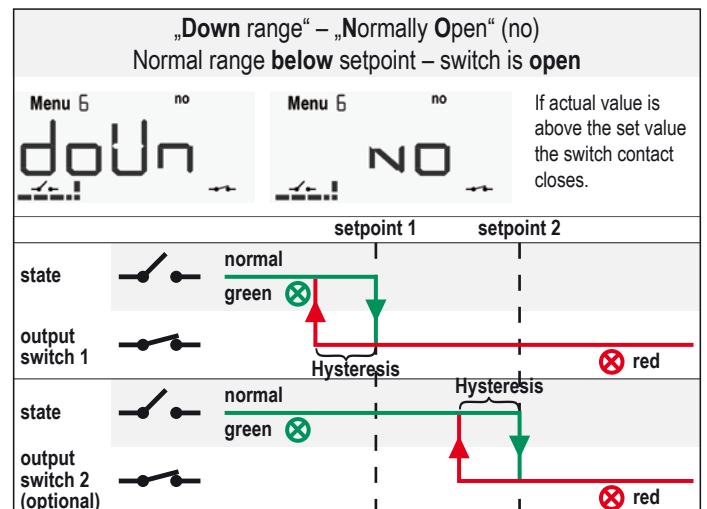
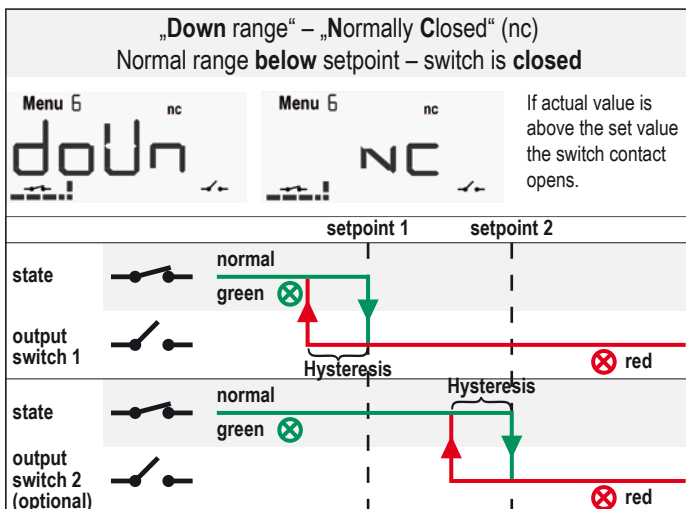
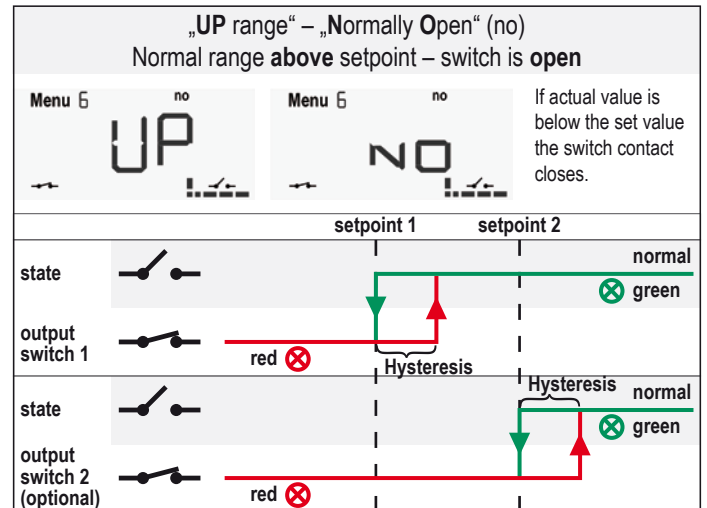
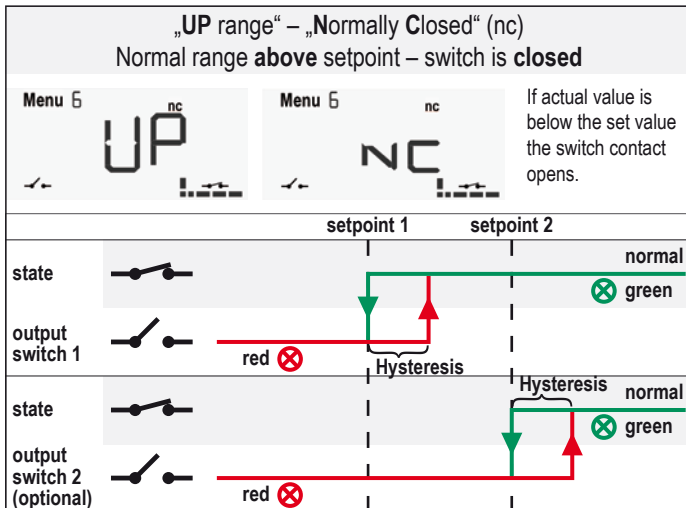

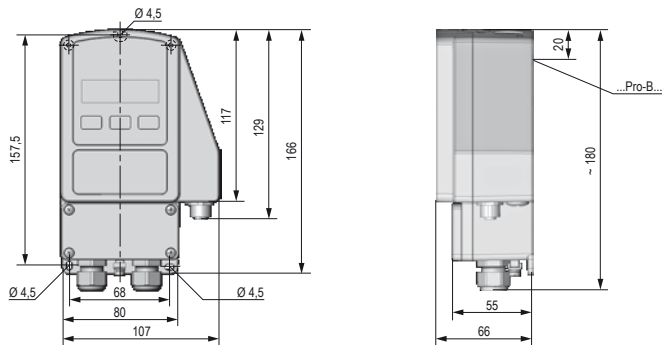
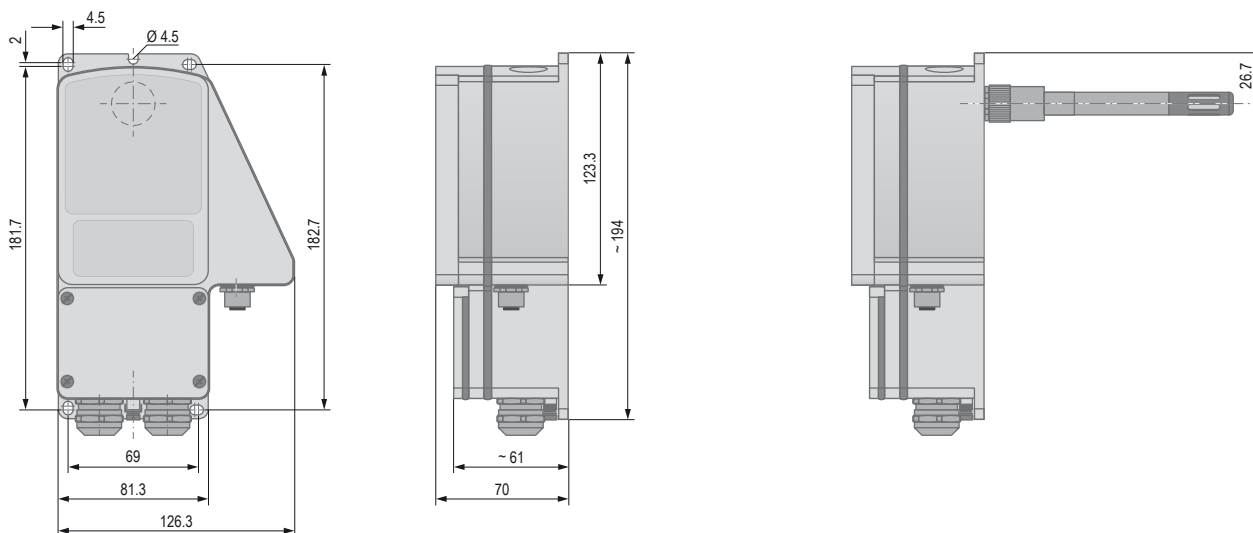
Dimensions [mm]
Aluminium housing

Stainless steel housing

Approbations

| | |
|-----------------------------|--|
| ATEX directive | 2014/34/EU |
| EC type-approved | EPS 14 ATEX 1 658 |
| IECEX certified | IECEX EPS 14.0075 |
| Approval for gas | II 3 (1) G Ex nC [ja Ga] IIC T6...T4 Gc |
| Types ...-CT | II 3 (1) G Ex nC [ja Ga] IIB T6 Gc |
| Approval for dust | II 3 (1) D Ex tc [ja Da] IIIC T80°C...T130°C Dc IP66 |
| CE identification | CE № 0158 |
| EMC directive | 2014/30/EU |
| Enclosure protection | IP66 in acc. with EN 60529 |

| | | |
|-----------------------|---|--------------------------|
| EAC | TC RU C-DE.ГБ08.В.01510 | |
| CSA | 13.2672226 | Aluminium housing |
| Class Division | Class I, Division 2, Groups ABCD, T6, IP66 | |
| | Ex nA [ja Ga] IIC Gc | |
| Types ...-CT | Ex nA [ja Ga] IIB Gc | |
| Class Zone | Class I, Zone 2, AEx nA [ja Ga] IIC T6 Gc, IP66 | |
| Types ...-CT | Class I, Zone 2, AEx nA [ja Ga] IIB T6 Gc, IP66 | |